

inTank Ballast Water Treatment System

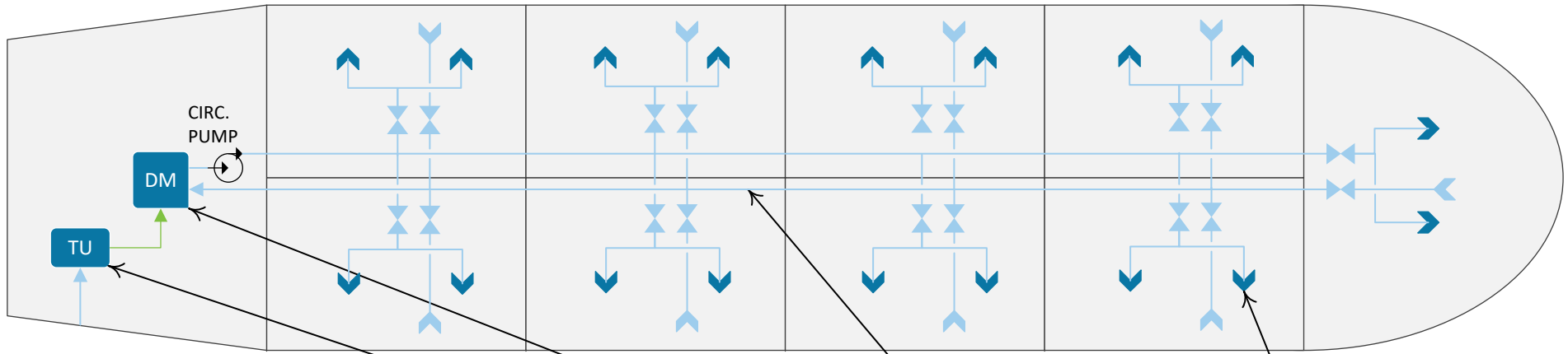

Distribution Piping
 Supply (Nozzle Header)
 Return (Ballast Main Header)

Typical inTank Outfitting:
 (1) Suction
 (2) to (4) Mixing Nozzles

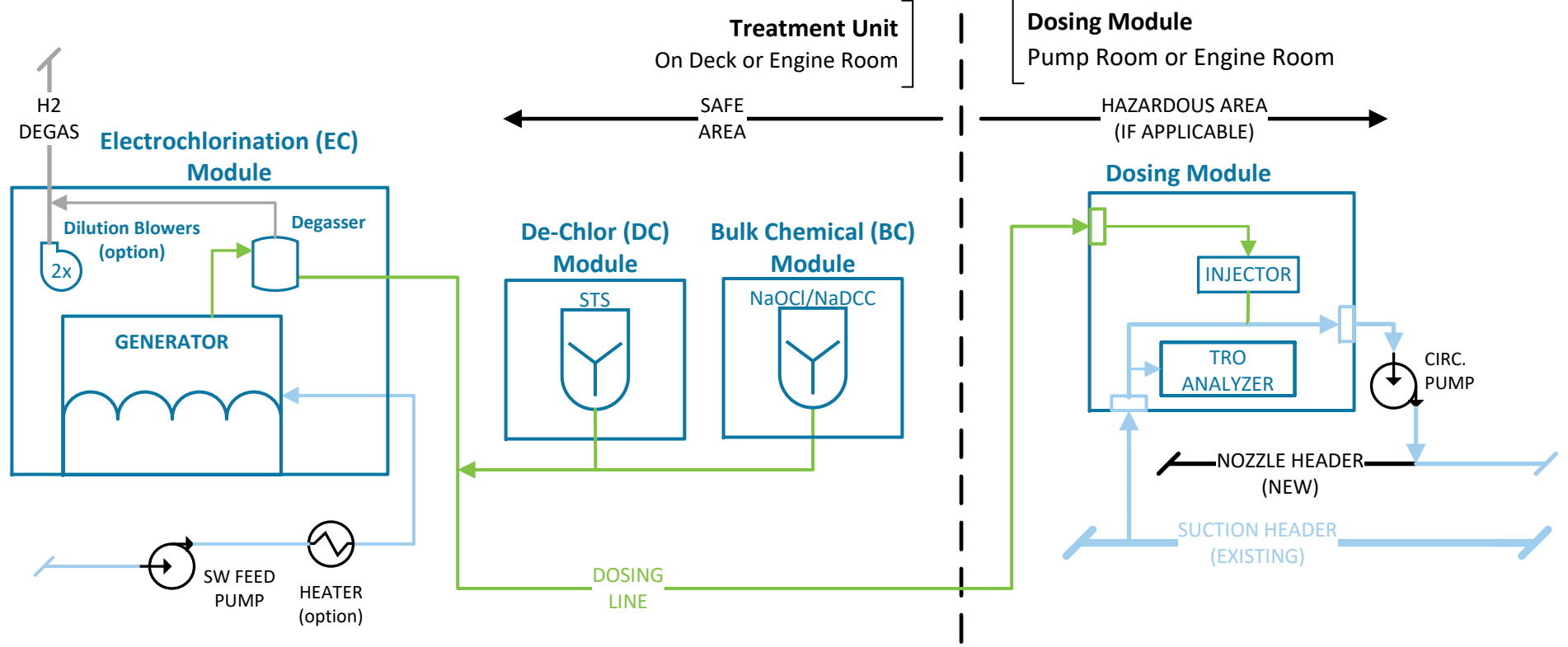

Treatment Unit
 On Deck or Engine Room

Dosing Module
 Pump Room or Engine Room

← SAFE AREA →

← HAZARDOUS AREA (IF APPLICABLE) →

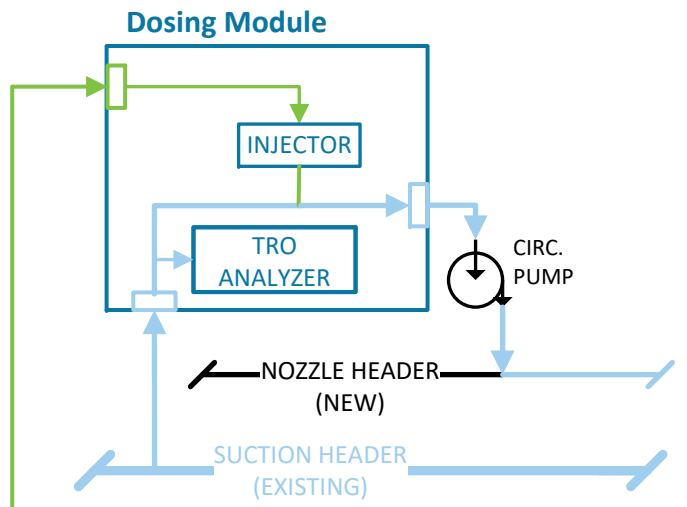
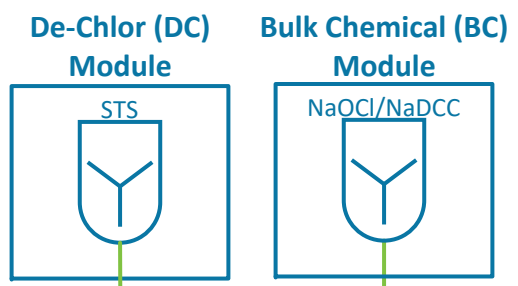
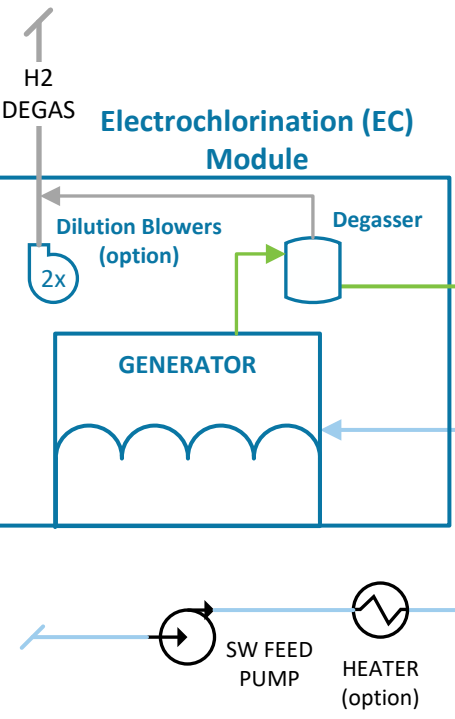

DOSING LINE

TREATMENT UNIT

SAFE AREA

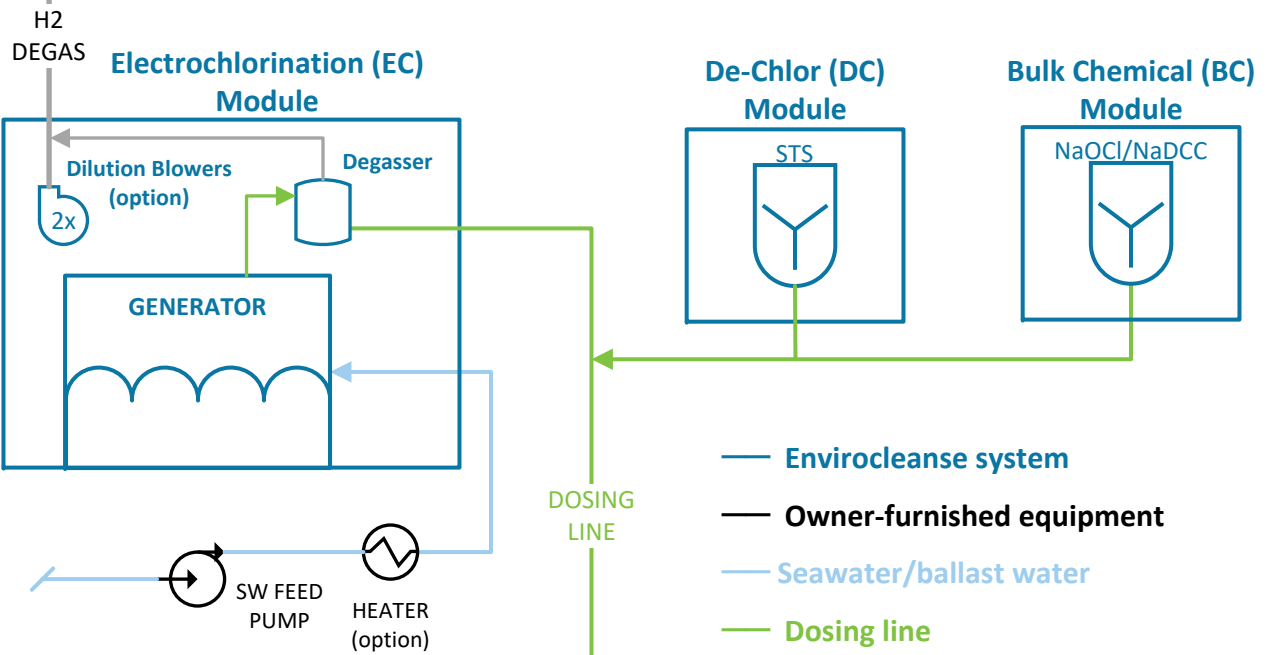

- Envirocleanse system
- Owner-furnished equipment
- Seawater/ballast water
- Dosing line

HAZARDOUS AREA (IF APPLICABLE)

